

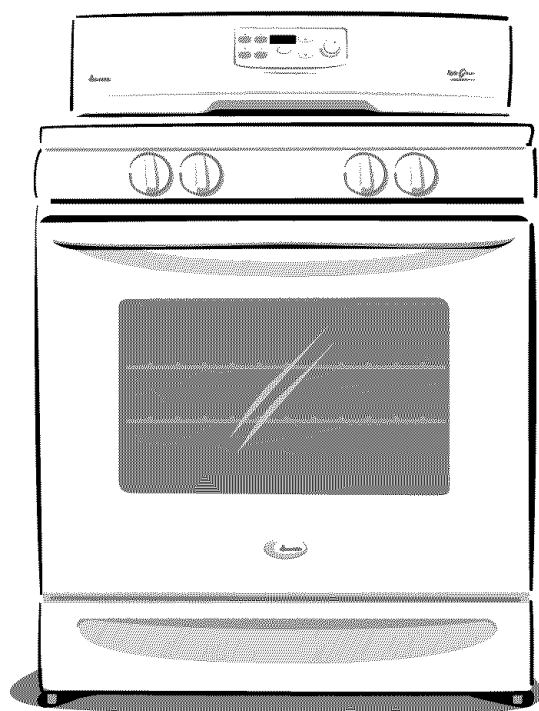

Owner's Manual

Covering **Amana** Distinctions™ DCF3305A

and **The Big Oven**™ ACF3325A



The Big Oven™

Gas Range

Keep instructions for future reference.
Be sure manual stays with range.

Contents

Important Safety Information	3
Adjusting Burner Flame	6
Cookware Suggestions	8
Using the Range	9
Custom Features	12
Displays and Signals	13
Using the Oven Control	14
Cooking	
Baking	19
Broiling	22
Roasting	23
Braising	24
Care and Cleaning	25
Troubleshooting	28
Amana Warranty	30
Manuel du propriétaire	31

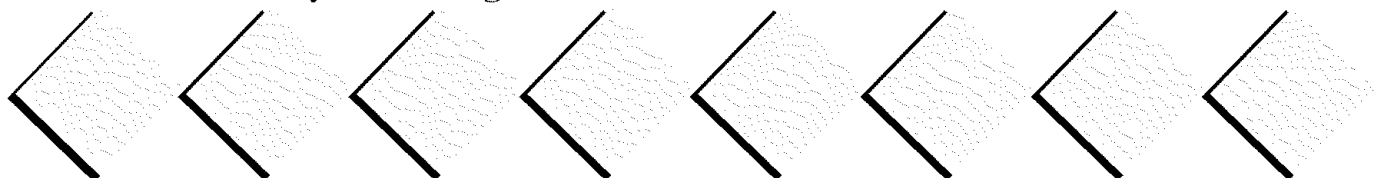

Thank you for buying an Amana Range!

Please take the time to complete the registration card and return promptly. If registration card is missing, call Amana Consumer Affairs Department. When contacting Amana, provide product information from serial plate found on right side of storage door opening:

Model Number _____
Manufacturing (P) Number _____
Serial Number (S/N) _____
Purchase Date _____
Dealer Name _____
Dealer Address _____
Dealer Phone _____

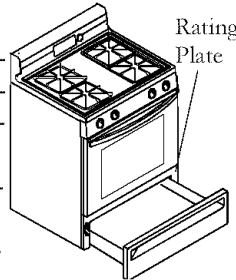

Keep this manual and your sales receipt together in a safe place for future reference or if warranty service is required.

For answers to questions or to locate an authorized servicer, call **1-800-NAT-LSVC (1-800-628-5782) inside USA or 319-622-5511 outside USA. Warranty service must be performed by an authorized servicer.** Amana Appliances also recommends contacting an authorized servicer if service is required after warranty expires.

Asure™ Extended Service Plan

Amana Appliances offers long-term service protection for this new range. Asure™ Extended Service Plan, covering functional parts, labor, and travel charges, is specially designed to supplement a strong warranty. Call 1-800-528-2682 for information.

Parts and Accessories

Purchase replacement parts and additional accessories such as cleaning supplies by phone. To order accessories for your Amana product, call 1-800-843-0304 inside USA or 319-622-5511 outside USA.

Save Time and Money

If something seems unusual, please check “Troubleshooting” section, which is designed to help you solve problems before calling service. If you have a question, call us at **(800) 843-0304** or write us at:

Consumer Affairs Department
Amana Appliances
2800 - 220th Trail
Amana, Iowa 52204

Remember to include model number of your appliance and your phone number.

To register your product electronically, get more information on your range or other Amana products, visit our Web site

www.amana.com

or

call Consumer Affairs Department at
1-800-843-0304

What You Need to Know about Safety Instructions

Warning and Important Safety Instructions appearing in this manual are not meant to cover all possible conditions and situations that may occur. Common sense, caution, and care must be exercised when installing, maintaining, or operating range.

Always contact your dealer, distributor, service agent, or manufacturer about problems or conditions you do not understand.

Recognize Safety Symbols, Words, Labels



DANGER

DANGER—Immediate hazards which **WILL** result in severe personal injury or death.



WARNING

WARNING—Hazards or unsafe practices which **COULD** result in severe personal injury or death.



CAUTION

CAUTION—Hazards or unsafe practices which **COULD** result in minor personal injury or product or property damage.

IMPORTANT SAFETY INFORMATION

WARNING

To reduce risk of the appliance tipping, it must be secured by a properly installed anti-tip bracket. To verify bracket has been installed properly, remove the storage drawer or panel and look under the range with a flashlight. Bracket must be engaged in the rear corner of the range.

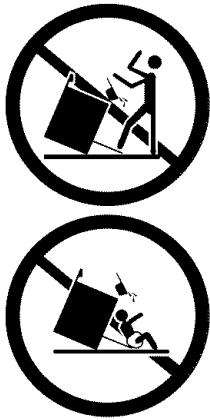

- ALL RANGES CAN TIP
- INJURY TO PERSONS COULD RESULT
- INSTALL ANTI-TIP BRACKET PACKED WITH RANGE
- REFER TO INSTALLATION INSTRUCTIONS

WARNING

To avoid personal injury, do not sit, stand or lean on oven door or oven drawer.

WARNING

To avoid risk of electrical shock, personal injury, or death, verify your range has been properly grounded and always disconnect it from main power supply before servicing.

WARNING

If the information in this manual is not followed exactly, a fire or explosion may result causing property damage, personal injury or death.

— Do not store or use gasoline or other flammable vapors and liquids in the vicinity of this or any other appliance.

— **What To Do If You Smell Gas**

- Do not try to light any appliance.
- Do not touch any electrical switch.
- Do not use any phone in your building.
- Immediately call your gas supplier from a neighbor's phone. Follow the gas supplier's instructions.
- If you cannot reach your gas supplier, call the fire department.

— Installation and service must be performed by a qualified installer, service agency or the gas supplier.

CAUTION

DO NOT TOUCH SURFACE BURNERS OR AREAS NEAR BURNERS—Areas near surface burners may become hot enough to cause burns. During and after use do not touch, let clothing or other flammable materials touch or contact surface burners or areas near surface burners until they have had enough time to cool. These areas include the rangetop and backguard.

CAUTION

DO NOT TOUCH GAS BURNERS OR INTERIOR SURFACES OF OVEN—Interior surfaces of an oven become hot enough to cause burns. During and after use do not touch, let clothing or other flammable materials touch, or contact heated interior surfaces of the oven until they have had enough time to cool. Other range surfaces that may become hot enough to cause burns are the oven door and oven vent at the backguard.

CAUTION

To avoid fire or smoke damage,

- remove any flammable materials from storage drawer. Items like plastic containers and paper manuals can melt or burn.
- clean excess spills before starting a self-clean cycle.

SAVE THESE INSTRUCTIONS

IMPORTANT SAFETY INFORMATION (cont'd)

ALL APPLIANCES

1. Proper Installation—Be sure your appliance is properly installed and grounded by a qualified technician.
2. Never Use Your Appliance for Warming or Heating the Room.
3. Do Not Leave Children Alone—Children should not be alone or unattended in the area where the appliance is in use. They should never be allowed to sit or stand on any part of the appliance.
4. Wear Proper Apparel—Loose fitting or hanging garments should never be worn while using appliance.
5. User Servicing—Do not repair or replace any part of the appliance unless specifically recommended in the manual. All other servicing should be referred to a qualified technician.
6. Storage in or on Appliance—Flammable materials should not be stored in an oven or near surface units.
7. Do Not Use Water On Grease Fires—Smother fire or flame, or use dry chemical or foam-type extinguisher.
8. Use Only Dry Potholders—Moist or damp potholders on hot surfaces may result in burns from steam. Do not let potholder touch elements. Do not use a towel or other bulky cloth.

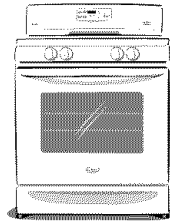

SURFACE BURNERS

1. Use Proper Pan Size—This appliance is equipped with one or more surface burners of different sizes. Select utensils having flat bottoms large enough to cover the surface burner. The use of undersized utensils will expose a portion of the burner to direct contact and may result in ignition of clothing. Use of oversized utensils concentrates heat on cooking surface and can cause damage to range. Proper relationship of utensil to burner improves efficiency.
2. Never Leave Surface Burners Unattended—Boilover causes smoking and greasy spillovers that may ignite.
3. Make Sure Reflector Pans or Drip Bowls Are in Place—Absence of these pans or bowls during cooking may subject wiring or components underneath to damage.
4. Protective Liners—Do not use aluminum foil to line surface burner drip bowls or oven bottom, except as suggested in the manual. Improper installation of these liners may result in a risk of electric shock, or fire.
5. Glazed Cooking Utensils—Only certain types of glass, ceramic, earthenware, or other glazed utensils are suitable for rangetop service without breaking due to sudden change in temperature.
6. Utensil Handles Should Be Turned Inward and Not Extended Over Adjacent Surface Burners—To reduce the risk of burns, ignition of flammable materials, and spillage due to unintentional contact with the utensil, the handle of a utensil should be positioned so that it is turned inward, and does not extend over adjacent surface burners.

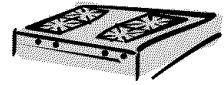

California Safe Drinking Water and Toxic Enforcement Act (Proposition 65)

The Governor of California is required to publish a list of substances known to the state of California to cause cancer or reproductive harm and requires businesses to warn customers of potential exposures to such substances.

This appliance may contain or produce a chemical or chemicals which can cause death or serious illness and which are known to the State of California to cause cancer, birth defects, or other reproductive harm. To reduce the risk from substances in the fuel or from fuel combustion, make sure this appliance is installed, operated and maintained according to the instructions provided.



CAUTION

To avoid delayed or improper ignition, do not obstruct the flow of combustion or ventilation air.



CAUTION

Do not store items of interest to children in cabinets above a range or on the backguard of a range—children climbing on the range to reach items could be seriously injured.

SAVE THESE INSTRUCTIONS

IMPORTANT SAFETY INFORMATION (cont'd)

OVENS

1. Use Care When Opening Door—Let hot air or steam escape before removing or replacing food.
2. Do Not Heat Unopened Food Containers—Build-up of pressure may cause container to burst and result in injury.
3. Keep Oven Vent Ducts Unobstructed.
4. Placement of Oven Racks—Always place oven racks in desired location while oven is cool. If rack is removed while oven is hot, do not let potholder contact hot heating element in oven.
5. Protective Liners—Do not use aluminum foil to line drip bowls, oven racks or oven bottoms. Improper installation of these liners may result in a risk of electrical shock, or fire.

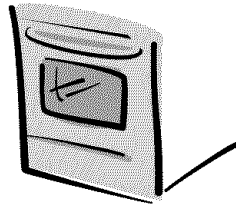

SELF-CLEANING OVENS

1. Do Not Clean Door Gasket—The door gasket is essential for a good seal. Care should be taken not to rub, damage, or move the gasket.
2. Do Not Use Oven Cleaners—No commercial oven cleaner or oven liner protective coating of any kind should be used in or around any part of the liner.
3. Clean Only Parts Listed in Manual.
4. Before Self-Cleaning the Oven—Remove broiler pan, oven racks, and other utensils.
5. Remove All Items From Rangetop and Backguard.

VENTILATION HOODS

1. Clean Ventilating Hoods Frequently—Grease should not be allowed to accumulate on hood or filter.
2. When flaming foods under the hood, turn the fan on.

DELAYED IGNITION

Surface burners

Burner should ignite within 4 seconds. If burner does not ignite within 4 seconds, turn control knob to OFF and follow directions for installing burner caps in Adjusting Surface Burners. Try again. If burner still does not ignite within 4 seconds, contact an authorized servicer.

Bake and broil burner flame

Allow no more than 40-60 seconds before burner ignites and heat is felt. To check for heat, open oven door to first stop and place hand over oven door. If heat is not felt, turn temperature control knob to OFF. If burner repeatedly fails to ignite, contact an authorized servicer.

In Case of Fire

Fires can occur as a result of over cooking or excessive grease. Though a fire is unlikely, if one occurs, proceed as follows:



Surface Burner Fire

1. Smother the fire with a nonflammable lid or baking soda, or use a Class ABC or BC extinguisher. Not water. Not salt. Not flour.
2. As soon as it is safe to do so, turn the surface controls to OFF. Turn off power at main circuit breaker or fuse box. Turn off gas supply.

Oven Fires

1. If you see smoke from your oven, do not open oven door.
2. Turn off oven.
3. As an added precaution, turn off power at main circuit breaker or fuse box. Turn off gas supply.
4. Turn on vent to remove smoke.
5. Allow food or grease to burn itself out in oven.
6. If smoke and fire persist, call fire department.
7. If there is any damage to components, call an authorized servicer before using range.



Precautions

- Do not cook food directly on rangetop surface, always use cookware.
- Do not mix household cleaning products. Chemical mixtures may interact with objectionable or even hazardous results.
- Do not put plastic items on warm cooking areas. They may melt and stick.
- Oven door contains a glass window. While the window is built to be sturdy and strong, it is still glass and needs to be treated with care.
- Do not lift or move range by grasping oven door handle. This can result in window glass breaking or shattering.
- Do not slide rough metal objects across rangetop surface. Scratching or metal marking can result.
- Do not leave fat heating unless you remain nearby. Fat can ignite if overheated by spilling onto hot surfaces.
- Do not allow pots to boil dry as this can cause damage to cooking surface and pan.
- Do not use rangetop surface as a cutting board.
- Do not use range for storage or as a display counter.

SAVE THESE INSTRUCTIONS

Adjusting Surface Burner Flame

Adjustments must conform to all local, municipal and state building codes, and local utility regulations.

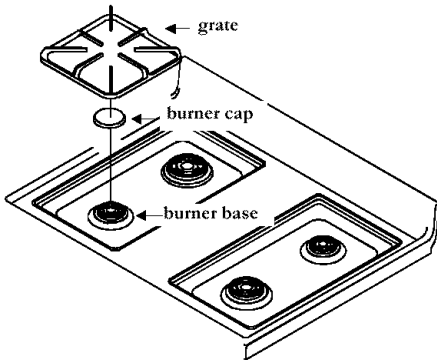

Placing burner caps

Burner cap must be correctly seated on the burner base for proper operation of the burner. Verify cap is properly aligned and leveled by moving the burner cap around on burner base while rangetop is cool.

- The cap should not be loose.
- The pegs in the burner base should fit into the recess on the underside of burner cap.
- Cap should be the correct size for each burner base.
- Cap must be clean and dry for proper ignition.
- Place grate over cap and burner base once cap is properly placed.

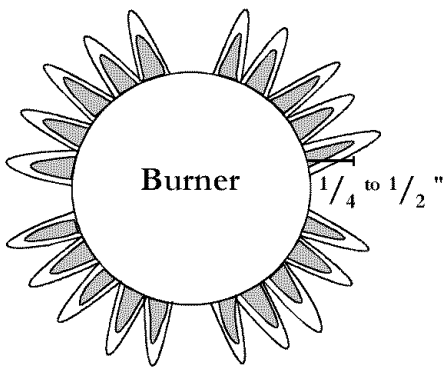

Testing and adjusting surface burner flame

A properly adjusted surface burner on a high setting has flames that are clean and blue with a distinct inner cone approximately $\frac{1}{4}$ to $\frac{1}{2}$ inch long. Some yellow flame is normal when burning LP/Propane.

- See *Delayed Ignition* section in Important Safety Information for safety warnings and procedures.
- **Flames will not be a uniform size around the cap. This distribution around the cap and grate allows for optimal heating.**
- If burner flame is blowing or noisy, airflow should be reduced to the burner (close air shutter).
- If burner flame is weak and does not hold its shape, airflow should be increased to the burner (open air shutter).

Adjusting the surface burner's air shutter

1. Disconnect electrical supply
2. Turn off all surface burners.
3. Remove burner control knobs from range.
 - 2 screws are visible on the burner control panel.
4. Remove both screws from burner control panel.
 - Panel will drop slightly after screws are removed.
5. While grasping bottom of burner control panel, gently lift and pull out panel until it is clear of burner valve stems.
 - After burner control panel clears the valve stems, continue to roll the panel until free from the range. Set aside.
 - Both gas valve and orifice hood are visible after burner control panel is removed.
6. Slide air shutter open or closed depending on the appearance of burner flame.
 - Air shutter should be moved by $\frac{1}{16}$ " to $\frac{1}{8}$ " at a time.
7. Connect electrical supply.
8. Check flame adjustment.
 - Slide knob onto valve shaft and turn to lite surface burner.
 - Flame should be blue with a distinct inner cone $\frac{1}{4}$ " to $\frac{1}{2}$ " long.
 - Shut off burner after flame is viewed. Remove knob. Disconnect electrical supply if further adjustments are needed.
 - Repeat air shutter adjustments as necessary.
9. Reassemble burner control panel in reverse order.

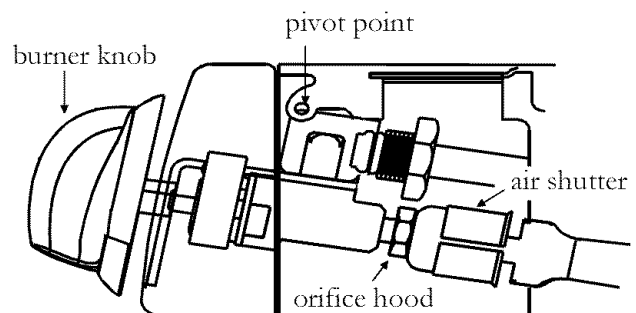
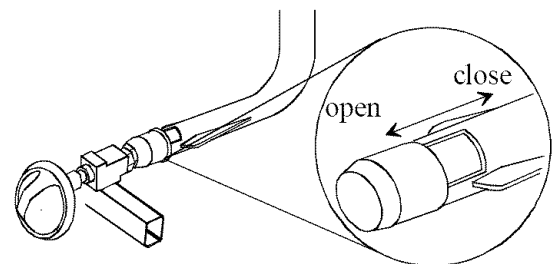

Adjusting Oven Burner Flame

Adjustments must conform to all local, municipal and state building codes, and local utility regulations.

Testing and adjusting the bake and broil burner flames

Properly adjusted oven burner flames are blue with a distinct blue inner cone approximately $\frac{1}{2}$ " long. When using natural gas, flame should not have any yellow flame when burning. Some yellow flame when burning LP/Propane gas is normal.

Flame should not be visible in oven cavity when burning and should not extend into the oven cavity beyond the removable oven bottom.

See *Delayed Ignition* section in Important Safety Information for safety warnings and procedures.

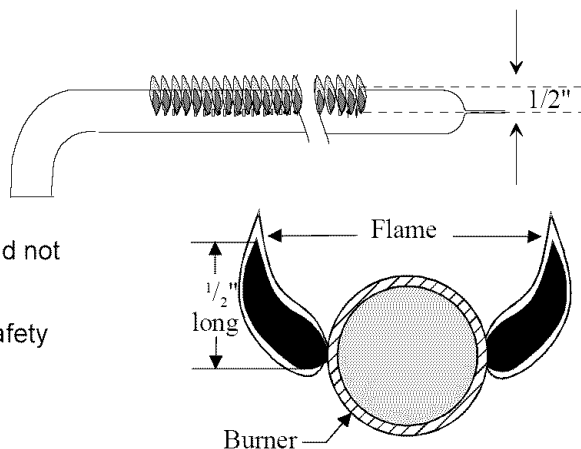

Adjusting bake burner's air shutter

1. Disconnect electrical supply.
2. Remove oven bottom while still cool.
3. Remove storage drawer.
4. From front of range, locate bake burner air shutter.
5. Loosen air shutter lock screw and open or close air shutter.
 - Air shutter should be moved by $\frac{1}{16}$ " to $\frac{1}{8}$ " at a time.
 - If burner flame is blowing or noisy, reduce airflow to the burner (close air shutter)
 - If burner flame is yellow and does not hold its shape, increase airflow to the burner (open air shutter).
6. Tighten air shutter screw.
7. Connect electrical supply.
8. Test oven bake burner flame for proper adjustment. If not adjusted properly, disconnect electrical supply and repeat steps 5, 6 and 7.
9. Replace storage drawer.
10. When oven is again cool, replace oven bottom.

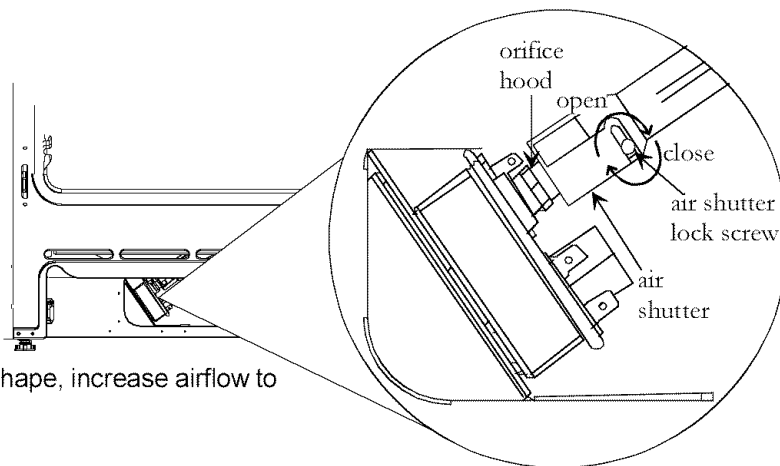

Adjusting broil burner's air shutter

1. Disconnect electrical supply.
2. Open oven door.
3. Loosen air shutter lock screw and open or close the air shutter.
 - Air shutter should be moved by $\frac{1}{16}$ " to $\frac{1}{8}$ " at a time.
 - If burner flame is blowing or noisy, reduce airflow to the burner.
 - If burner flame is yellow and does not hold its shape, increase airflow to the burner.
4. Tighten air shutter screw.
5. Reconnect electrical supply.
6. Test oven broil burner flame for proper adjustment. If not adjusted properly, disconnect electrical supply and repeat steps 3 and 4.
7. Close oven door.

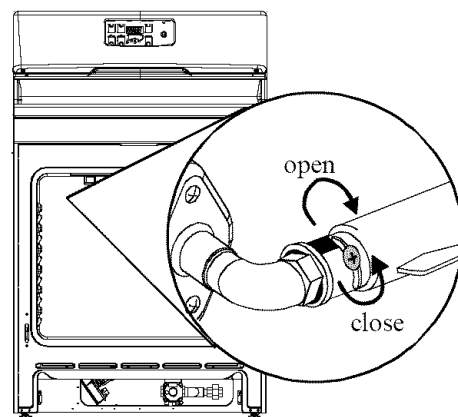

Cookware Recommendations

What Should You Consider in Cookware?

Flat Pan Test

For best cooking results, use a pan with a flat bottom. To determine if pan has a flat bottom:

1. Rotate a ruler along bottom of pan. If pan is not flat, gaps between bottom of pan and edge of ruler can be seen.
2. A small groove or mark on a pan does not affect cooking times. However, if a pan has a gap, formed rings, or an uneven bottom, it does not cook efficiently and in some cases may not boil liquid.

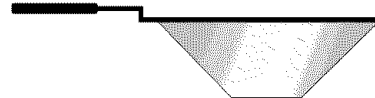
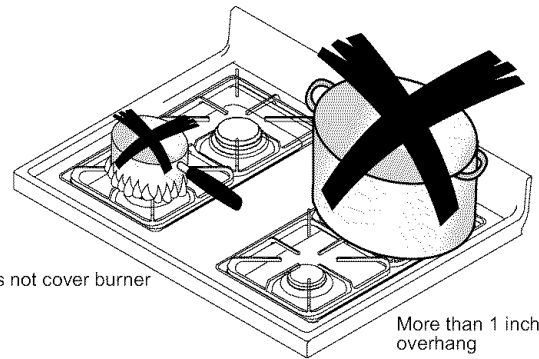
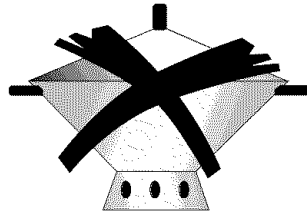
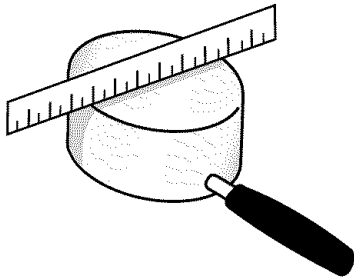

Can I can?

Canning is not recommended with any of the Amana gas ranges or cooktops due to the intense heat and large cookware required to can.

The high, sustained heat generated by the canning cookware overheats both the burners and the surface of the range or cooktop. This may cause damage to burners, knobs, or finish, and may even cause overheating of surrounding walls.

Damage incurred by canning, or attempting to can, is not covered under warranty.

SELECT	AVOID
Flat bottomed cookware.	Cookware with rounded or warped bottoms.
Heavy gauge metal cookware.	Light gauge metal cookware.
Handles that are secure, that are not heavy enough to tilt pan.	Cookware with loose or broken handles or heavy handles that tip pan when empty.
Proper pan size.	Cookware that is smaller than or greater than burner grate by 1 inch.
Flat bottomed wok	Wok with a ringstand on bottom.

COOKWARE MATERIAL	USES
Aluminum	Heats and cools quickly. Use for frying, braising, and roasting.
Stainless Steel	Heats and cools at moderate rate. Use for soups, sauces, vegetables, general cooking.
Copper Clad / Tin Lined	Heats and cools quickly. Use for gourmet cooking, wine sauces, egg dishes.
Cast Iron	Heats and cools slowly. Use for low heat cooking, frying.
Enamelware	Heating speed depends on base metal in the cookware. Use for low heat cooking.
Ceramic (Glass)	Heats and cools slowly. Use for low heat cooking.

Using the Range

Setting Surface Burner Controls

Burner should ignite within 4 seconds. If burner does not ignite within 4 seconds, turn control knob to OFF position and follow directions in *Placing Burner Caps* section.

1. Push in and turn knob to LITE.
 - Burner should ignite within 4 seconds.
2. After gas ignites, turn control to desired setting.
 - Knobs do not have distinct 'clicks'.
 - Use HI to bring food to boiling temperatures. When food is boiling temperature setting should be reduced.
 - After lighting burner do not operate for long periods of time without cookware on grate. The finish on the grate can chip without cookware to absorb the heat.
 - Flame size should match the size of the pan. Do not allow the flame to extend up the sides of the pan. This can cause clothing to ignite, make the handle hot, or cause burns.
3. When finished cooking, turn control to OFF position.

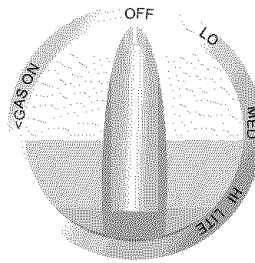

WARNING

To avoid risk of serious personal injury, property damage, or fire, do not leave surface burners unattended while in operation. Grease and spillovers can ignite causing a fire.

? **If These Controls Are Different From Yours**

The control descriptions are intended to show the variety of features that are available in the product line. If your range does not have all the features that are shown, it is not a mistake. The information provided applies to several of the available models.

SURFACE BURNER CONTROL SETTINGS	WHEN TO USE SETTING
LO	Use to prepare food at less than boiling temperatures or to simmer.
MED	Use to maintain boiling of larger amounts of food, low temperature frying and to maintain correct pressure in a pressure cooker.
HI	Use to bring food to boiling temperatures. When food is boiling temperature setting should be reduced to LO through MED.

During a Power Outage

Although the system that lights the burners is electric, surface burners can be ignited during a power outage. **Never attempt to light bake or broil burners (oven burners) during a power failure.**

1. Hold match at base of desired surface burner.
2. Push in burner control knob and turn to LITE position.
3. After gas ignites, remove match from burner and turn burner control knob to desired setting.

Adjusting Burner Flame Size

- While turning burner control knob, watch the burner flame.
- Flame size should match the size of the pan.
- Flames that extend up the sides of the pan can ignite clothing, making the handle hot, or cause burns.

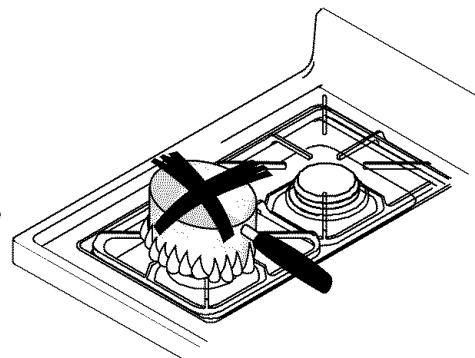

Using the Range (cont'd)

Aluminum Foil



WARNING

To avoid risk of personal injury, property damage or fire, do not line oven bottom, racks, or broiler pan and grid with aluminum foil or any other material.

When placed on the oven bottom or racks, aluminum foil not only creates a hazard, but also affects cooking performance. To minimize spills in the oven, place a shallow pan or cookie sheet underneath food items that drip or spill.

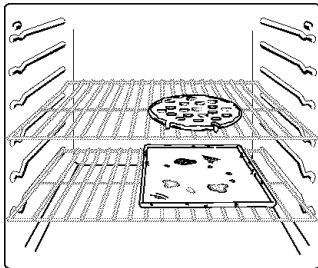

Broiling Hints

- Broiling does not require preheating.
- Remove excess fat from meat before broiling.
- Cut edges of meat to prevent curling.
- Place food on a cold ungreased broiling pan. If pan is hot, food sticks.
- All food except fish should be turned at least one time.
- Begin broiling with skin side down.
- Season meat after it has browned.
- Begin cooking using suggested rack levels in *Cooking: Broiling* section in the back of this manual to test broiler results. If food is not brown enough, cook on a higher rack position. If food is too brown, cook on a lower rack position.
- Oven door must be closed.

Oven Racks and Rack Positions

Your range has 5 oven rack positions to accommodate all type of cooking and cookware. **Top oven rack position must not be used.**

Oven Rack Placement

Position oven rack before turning oven on.

1. Pull rack forward to stop position.
2. Raise front edge of rack and pull until rack is out of oven.
3. Place rack in new rack position.
 - Curved edge of rack must be toward rear of oven.

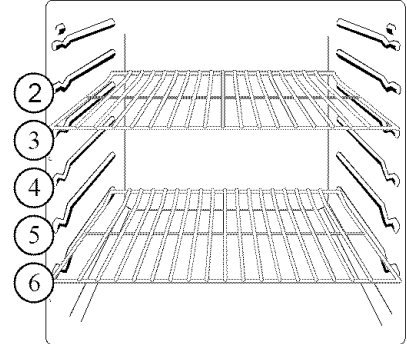

RACK POSITION GUIDELINES FOR BAKING, ROASTING, BRAISING

Rack Position	Food Type
2	Puff pastry products, streudles, casseroles, muffins, small pork loin, and Eye of Round roast.
3	Halved chickens, whole pork tenderloin, Cornish hens, pot pies, frozen pizzas, quick breads (corn bread, biscuits).
4	Roast tenderloin of beef, whole chicken, whole pork loin, roasted vegetables such as spaghetti or acorn squash.
5	Whole turkey, capons, tip roasts and dressings.
6	Large cuts of roasts meats such as top round, standing rib roast, crown roast of lamb and boston butts. Baked and sweet potatoes, flat breads and cobblers.

RACK POSITION GUIDELINES FOR BROILING

Rack Position	Food Type
2	Boneless pork chops, boneless skinless chicken breast, fish fillets, tuna steaks. Use a flat or shallow edged tray. 1/2 to 3/4" thick beef or tuna steaks, or pork chops. London Broil.
3	1 to 1 1/2" thick steaks, 1 to 2" thick pork chops. Lobster tails.

Using the Range (cont'd)

Placing the oven bottom

The oven bottom in your range has been screwed in to prevent any shifting during moving or cooking. The oven bottom protects the recessed bake burner area during baking or broiling.

It is necessary to remove the oven bottom for routine cleaning. The oven bottom, burner baffle, and bake burner recess will need to be cleaned of any excess grease or soil before a self-clean cycle is started.

To remove the oven bottom:

1. Verify all controls are in the OFF position.
2. Oven must be cool to the touch.
3. Open oven door and adjust any low oven racks to a higher rack position, or remove racks temporarily from oven.
4. Locate two thumb screws holding oven bottom in place in rear of oven cavity.
 - Remove thumb screws and retain for later use.
5. Carefully remove oven bottom from oven cavity.
 - Lift at rear sides and slide from front frame.
 - Oven bottom can be washed of excessive grease using a mild soap and water.
6. Wipe out bake burner recess with a cloth dampened with soapy water.
7. Dry thoroughly.
8. Replace oven bottom and secure with thumb screws.
 - Place front edge of oven bottoms under front frame.
 - Lower rear of oven bottom into position and install thumb screws.
 - Do not overtighten thumb screws.
 - Oven bottom must be in place for oven to be used or for a self-clean cycle to be run.
9. If oven racks were removed, replace oven racks.

WARNING

To avoid risk of personal injury, property damage, or fire, clean excess grease and soil from bake recess before beginning a self-clean cycle.

WARNING

To avoid risk of personal injury, property damage or fire, do not line oven bottom, racks, or broiler pan and grid with aluminum foil.

CAUTION

To avoid risk of personal injury wear gloves to protect hands from possible sharp edges.

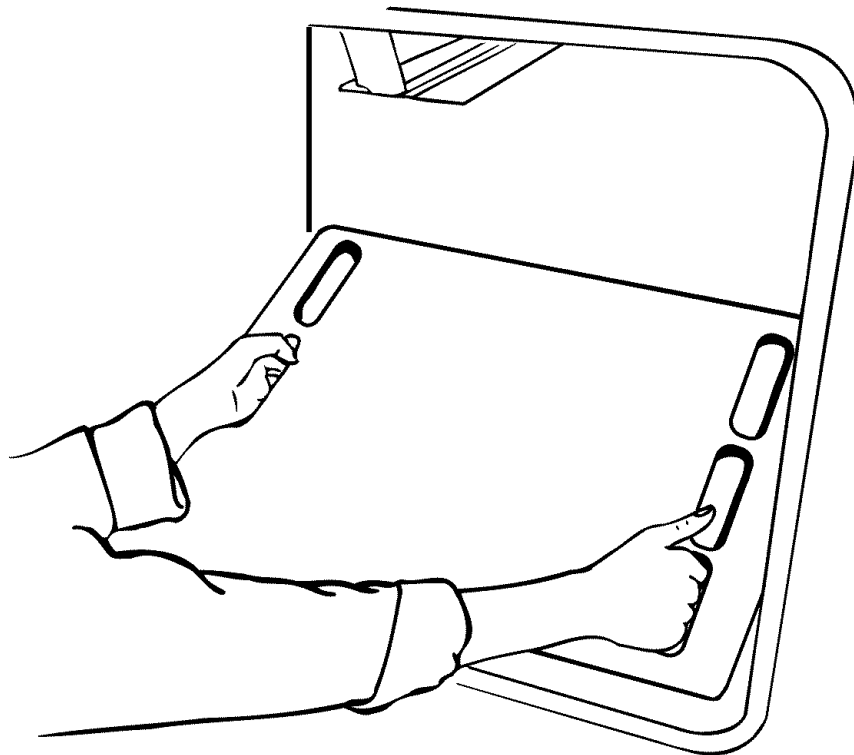

Features



12-hour automatic cancel

This safety feature prevents oven from continuing to operate if it has been left on for over 12 hours. If a cooking function continues longer than 12 hours without any options on oven control being touched, this feature turns oven off. Any time an option is touched, 12-hour automatic cancel is reset.

Oven temperature control adjustment

Your range is calibrated at the factory for proper temperature. Due to individual variances and preferences, it may be necessary to adjust oven once it has been installed.

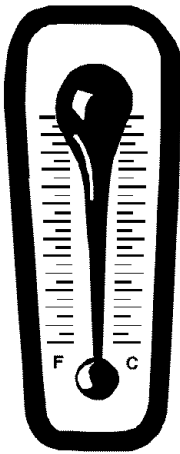

When first using the oven, follow recipe times and temperatures. Before adjusting oven baking temperature, test a recipe by setting oven temperature higher or lower than the suggested temperature. The baking results should help you to decide how much of a temperature adjustment is required.

An accurate digital thermometer is necessary to calibrate the oven. Store purchased oven thermometers do not accurately measure oven temperature. Oven temperature can be increased or decreased by 35°F. To avoid over adjusting the oven, only adjust the temperature by 5°F each time.

NOTE: Remove aluminum foil from racks and oven bottom as this will alter oven performance. Check for blocked heat vents. If it still appears oven is not performing as expected, a calibration may be done.

1. Turn oven temperature knob to OFF.
2. Press and hold both arrow pads for approximately 5 seconds.
3. A double digit will display ranging from -35°F to 35°F.
4. Immediately, press either:
 - ▲ to increase oven temperature by 5°F
 - ▼ to decrease oven temperature by 5°F
 - When temperature is adjusted to a cooler setting, a minus sign (-) will display with the offset temperature.
5. When desired temperature change is displayed, release control and change will be automatically saved after a few seconds. Control will return to time of day display.
 - Offset temperature change will be retained through a power failure.

Service codes and tones

Electronic oven control is equipped with a self-diagnostic system. Self-diagnostic system alerts you if there is an error or problem with the unit. If electronic range control sounds a series of short, rapid beeps for over 16 seconds and the display shows an F-code, record F-code shown. Some F-codes can be cleared by disconnecting power to the range for approximately 3 minutes. If the code continues to reoccur disconnect electrical supply to range and contact an authorized servicer.

F-code	Possible Meaning
F1	Control failure
F2	Oven over temperature
F3	Sensor open or shorted
F9	Door latch circuit failure
DOOR	Door has not latched.

Display and Signals

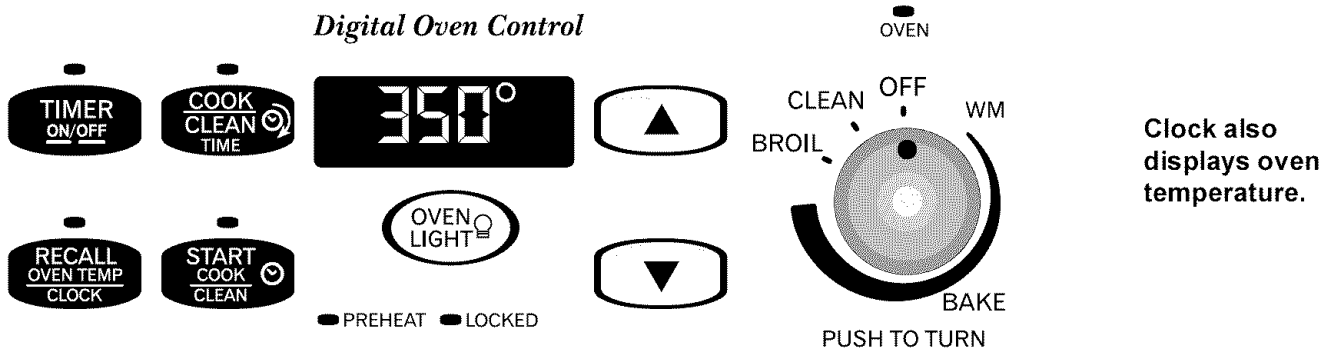

LIGHTS	DESCRIPTION
CLOCK	Clock pad light remains on while time of day is set.
TIMER ON/OFF	Timer On/Off pad light remains on while the timer counts down.
COOK/CLEAN TIME	Cook/Clean Time light is turned on when entering cook or clean time. Light remains on during the cook or clean cycle.
START COOK/CLEAN	Start Cook/Clean light turns on when entering the time a cooking or cleaning cycle is to start.
PREHEAT	Preheat light turns on and remains on while oven is heating to selected temperature. Light shuts off when oven reaches and maintains temperature.
LOCKED	Locked light turns on and remains on when oven door is locked. Locked light flashes when door is automatically locking or unlocking.
OVEN ON	Oven On light turns on and remains on while oven is in use. Oven light does not monitor oven cavity temperature.
OVEN LIGHT	Turns on when OVEN LIGHT pad is pressed.

Timer Signal

When time elapses, timer beeps a single, three second tone.

Preheat Signal

After setting oven to bake and selecting a temperature, oven preheats. When oven reaches set temperature, oven signals a one second beep and the preheat light shuts off.

End-of-Cycle Signal

When a timed cooking cycle is complete, the oven will beep four tones approximately one second apart, followed by a continuous series of one second beeps every ten seconds until the oven knob is turned to OFF.

DISPLAY	DESCRIPTION
BRL	Displays when oven is broiling or set to broil.
CLN	Displays when oven is self cleaning or is set to self clean.
END	Displays when oven has reached the end of a baking or cleaning cycle.

Using the Oven Control

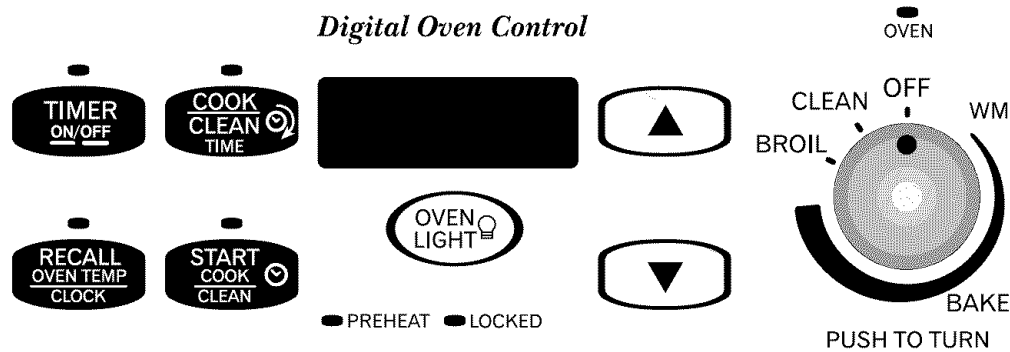

Flashing Display

When power is connected or interrupted, oven display flashes. Press **CLOCK** to reset display. Clock may need to be reset.

Making the Numbers Increase at a Faster Rate

Time increases in larger increments the longer the **▲** or **▼** pad is held.

Timer Signal

When time elapses, beep will sound. Press **TIMER ON/OFF** pad to stop timer and return to clock display.

Preheat Signal

After setting oven to bake and selecting a temperature, oven preheats. When oven reaches set temperature, signal sounds. The preheat light will shut off and remain off after oven has reached the selected temperature.

Setting Electronic Clock

The 12 hour clock does not display AM, PM or military time. When power is connected or restored, display flashes until **RECALL OVEN TEMP/CLOCK** pad is pressed or temperature knob is turned.

1. Press **RECALL OVEN TEMP/CLOCK** pad.
2. Press **▲** or **▼** pads until correct time-of-day displays.
3. Time is set after 5 seconds of no adjustment.



Setting Minute Timer

The timer is a timer only. Electronic timer does not control bake, broil or self-clean function. Timer can be set up to 11 hours and 59 minutes.

1. Press **TIMER ON/OFF** pad.
2. Press **▲** or **▼** pad until desired amount of time displays.
 - Time increases in 1 minute and 10 minute increments.
 - Timer begins counting down automatically after time is entered.
 - To view clock while timer counts down, press **RECALL OVEN TEMP/CLOCK** pad. Timer will return after 3 seconds of no input.
3. Press and hold **TIMER ON/OFF** pad to cancel timer signal.
 - After time elapses, timer beeps a single, three second tone.



Resetting and Canceling Timer

To reset the time when remaining time is displayed, press **TIMER ON/OFF** pad, then **▲** or **▼** pad until new time displays. To cancel timer when remaining time is displayed or when signal is beeping, press and hold **TIMER ON/OFF** pad.

Using the Oven Control (cont'd)

Baking

While oven is still cool, remove any stored items from the oven cavity.

1. Place racks in desired position and close oven door.
2. Push and turn oven temperature knob to desired temperature.
 - Oven indicator light will turn on and stay on.
 - Temperature is displayed in the clock area in 5 degree increments.
 - Temperature range is 170°F to 550°F.
 - Display will return to time of day after approximately 15 seconds.
 - To recall oven temperature, press RECALL OVEN TEMP/CLOCK pad.
3. PREHEAT light will turn on during the preheat cycle. PREHEAT light shuts off when oven has reached desired temperature and oven beeps.
4. Open door carefully and place food in oven.
5. After cooking time elapses, remove food and turn oven temperature knob to OFF.

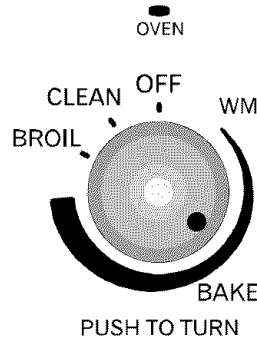

WARNING

To avoid risk of personal injury, property damage or fire, do not line oven bottom, racks, or broiler pan and grid with aluminum foil.



WARNING

To avoid risk of personal injury, property damage or fire, never leave oven unattended while broiling.

Preheating

In most cases, you should preheat the oven before baking. After the range control is set, the oven temperature will begin to rise until the desired cooking temperature is reached. When cooking temperature is reached oven signal beeps. For delicate baking, preheat approximately 15–20 minutes before placing food inside oven or wait 10 minutes after oven signal beeps before placing food in oven. The extra time creates a more stable oven temperature.

Broiling

Broiling sears in natural juices and provides charbroiled flavor.

To broil, center food on broiling grid and pan and place on proper rack in oven. Do not place aluminum foil over broiling pan, oven rack or oven bottom. **Oven door must be fully closed.** Broiling does not require preheating so you can place food in oven while it is still cool.

1. Adjust oven racks to desired position.
2. Turn oven temperature knob to BROIL.
 - Oven indicator light will turn on and remain on.
 - **BRL** will display.
 - Display will return to time of day after approximately 15 seconds after broiling begins.
 - To recall oven temperature, press RECALL OVEN TEMP/CLOCK pad.
3. Close oven door.
 - If oven door is ajar for more than 3 minutes, broil cycle will stop.
 - If oven stops broiling due to an open door, close oven door and wait for the ignitor to lite broil burner.
3. After broiling, remove food and turn oven temperature knob to OFF.

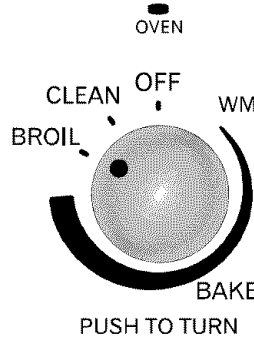

How High or Low Can I Set the Temperature?

Oven bake temperature can be set from 170°F to 550°F. Some minor smoking is normal when using oven for first time.

Using the Oven Control (cont'd)

What's the difference between TIMED and DELAYED cooking?

When using TIMED cooking, the oven begins to heat immediately after the oven control is set. Then, the oven cooks for the desired length of time set. When using DELAYED cooking, the oven begins to cook later in the day. Set the time that you want to begin cooking and the how long you want to cook. The oven begins to heat when at the selected time and cooks for the specified length of time.

How Far Ahead Can I Set the Time?

Cook time and start time can be set up to 11 hours and 59 minutes ahead. To view cook time, press and hold COOK TIME pad. When cooking time has elapsed, an end of cycle signal sounds, oven automatically turns off and display returns to time of day. Oven signal sounds 4 times, then once every 10 seconds until knob is turned to OFF. Broil can not be set to Timed or Delayed.



CAUTION

To reduce risk of food poisoning due to bacterial growth and production of toxins, never hold meat, milk, fish, or eggs for more than 2 hours before cooking.

How much time is left?

For a delayed bake cycle, the cook time can be viewed by pressing the COOK pad. For a timed bake cycle, the stop time can be viewed by pressing the STOP pad.

Timed Baking

Set oven to cook for desired amount of time. Follow recipe directions for preheating the oven.

1. Place food in oven.
2. Press COOK/CLEAN TIME pad.
3. Press ▲ or ▼ pad until desired length of time is displayed.
 - Cook time can be set up to 11 hours and 59 minutes.
4. Push and turn the temperature control knob.
 - Temperature displays in 5° increments starting at 170°F.
 - Clock will return to time of day after approximately 15 seconds.
 - To recall oven temperature, press RECALL OVEN TEMP/CLOCK pad.
5. Oven will automatically begin to heat.
 - To adjust cook time, press COOK/CLEAN TIME pad while the remaining cook time is displayed. Cook time can then be adjusted.
 - When cooking time has elapsed an end of cycle signal sounds and **END** will be displayed. Oven signal sounds 4 times, then once every 10 seconds until oven control knob is turned to OFF.
6. Turn knob to OFF to cancel baking.



Delayed Baking

Set oven to begin baking at a later time.

1. Place food in oven.
2. Press START COOK/CLEAN button.
 - Default time displayed is current time of day.
3. Press ▲ or ▼ pad until desired time displays.
 - Start time can be set up to 11 hours and 59 minutes ahead of current time of day.
4. Press COOK/CLEAN TIME pad.
5. Press ▲ or ▼ pad until desired cooking time displays.
 - 1 minute minimum cooking time.
 - **END** will be displayed when cooking time has elapsed.
6. Push and turn oven temperature control knob to desired temperature.
 - Temperature displays in 5° increments starting at 170°F.
 - Display will return to time of day after 5 seconds of no input.
 - START TIME and COOK TIME lights will remain on, but OVEN ON light will not turn on until cooking begins.
7. Oven will automatically begin to heat at selected start time.
 - OVEN ON light will turn on when oven begins to heat.
 - To adjust cook time, press COOK/CLEAN TIME pad while the remaining cook time is displayed. Cook time can then be adjusted.
 - When cooking time has elapsed an end of cycle signal sounds and **END** will be displayed. Oven signal sounds 4 times, then once every 10 seconds until oven control knob is turned to OFF.
8. Turn knob to OFF to cancel baking.



Using the Oven Control (cont'd)

Self-cleaning

Self-clean feature uses high oven temperature to clean oven interior. For the oven to operate through a complete self-clean cycle, the self-clean must be set when the oven is cool.

1. Prepare oven for self-cleaning (see below left).
2. Close door.
3. Push and turn oven temperature knob to CLEAN position.
 - The default self-clean cycle length of 3 hours will display.
4. Set cycle length for self-clean.
 - Use arrow keys to adjust time as necessary before oven indicator light turns on.
 - Clean cycle can be set from two to four hours in five minute increments.
 - Default setting for the cycle is three hours.
5. Self-clean begins.
 - OVEN ON indicator light will be on and will remain on until the end of the cycle.
 - At the end of the self-clean cycle, the OVEN ON indicator light will shut off.
 - The LOCKED indicator light will remain on until oven reaches a cooler temperature. LOCKED light will flash while door is unlocking, and then shut off when door has unlocked. Oven cavity will be hot to the touch. **DO NOT** attempt to open door prior to LOCKED indicator light shutting off.

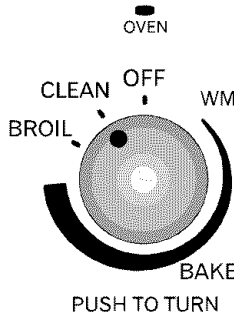

Interrupting the self-clean cycle

To stop a self-clean cycle that has already started follow these steps. If the interruption occurs mid cycle, the oven will remain locked, even though the cycle has stopped, until the oven cavity has cooled to a lower temperature.

1. Turn oven temperature knob to OFF position.
2. When oven has cooled to a lower temperature, LOCKED light turns off. Door can be unlocked. **DO NOT** force door. This can cause damage to the latch.

Operating surface burners during a self-clean cycle.

Your range is equipped with a safety feature to prevent it from overheating during a self-clean cycle. A special temperature sensor shuts off the self-clean cycle if the range becomes too hot. Depending on the range and the length of cooking time on the surface burners, the sensor may or may not shut off the self-clean cycle. To prevent any self-clean cycle disruption, it is best not to use the range surface burners during a self-clean cycle.

CAUTION

To avoid fire or smoke damage,

- remove any flammable materials from storage drawer. Items like plastic containers and paper manuals can melt or burn.
- clean excess spills before starting a self-clean cycle.

WARNING

To avoid risk of personal injury, do not touch oven vents, or area around vents, during self-cleaning. These areas can become hot enough to cause burns.

Do I need to prepare?

To get the best results from the self-clean cycle, follow these steps:

- Clean excess spills from oven interior and oven burner thoroughly.
- **Remove birds or animals susceptible to smoke or other fumes from the room or adjoining room.**
- Open window if possible.
- Make sure oven light cover is properly in place. Do not use cleaning cycle if it is not.
- Remove oven racks and all cooking utensils from oven.
- Remove items from range top, backguard and storage drawer. These areas can become hot during self-cleaning cycle.
- The range vents from the center bottom of the backguard. Make sure this area is unobstructed by removing all items from backguard and range top.

Using the Oven Control (cont'd)



WARNING

To avoid risk of personal injury, do not touch oven vents, or area around vents, during self-cleaning. These areas can become hot enough to cause burns.



CAUTION

To avoid fire or smoke damage,

- remove any flammable materials from storage drawer. Items like plastic containers and paper manuals can melt or burn.
- clean excess spills before starting a self-clean cycle.

Do I need to prepare?

To get the best results from the self-clean cycle, follow these steps:

- Clean excess spills from oven interior and oven burner well.
- **Remove birds or animals susceptible to smoke or other fumes from the room or adjoining room.**
- Open window if possible.
- Make sure oven light cover is properly in place. Do not use cleaning cycle if it is not.
- Remove oven racks and all cooking utensils from oven.
- Remove items from range top backguard and storage drawer. These areas can become hot during self-cleaning cycle.
- The range vents from the center bottom of the backguard. Make sure this area is unobstructed by removing all items from backguard and range top.

Delayed Self-clean Cycle

Self-clean feature uses high oven temperature to clean oven interior. Set oven to begin and end cleaning at later time. Range control begins the self-clean at your specified start time.

1. Prepare oven for self-cleaning (see below right).
2. Close door.
3. Press START COOK/CLEAN pad.
4. Set starting time for the cleaning cycle.
 - Default time is current time of day.
 - Start time can be set from current time to current time plus 11 hours and 59 minutes.
5. Turn oven temperature knob to CLEAN.
 - Default self-clean cycle length of 3 hours will display.
6. Set cycle length for self-clean.
 - Use arrow keys to adjust time as necessary.
 - Clean cycle can be set from two to four hours in five minute increments.
 - Default setting for the cycle is three hours.
7. Self-clean cycle is set.
 - Oven cannot be used until completion of the self-clean cycle.
 - Self-clean cycle will begin at selected start time.
 - To view start time, press the START COOK/CLEAN pad.
 - OVEN ON indicator light will turn on when the self-clean cycle begins and will remain on until the end of the cycle.
 - To view the clean cycle time, press the COOK/CLEAN TIME pad.
 - At the end of the self-clean cycle, OVEN ON indicator light shuts off.
 - The LOCKED indicator light will remain on until oven reaches a cooler temperature. LOCKED light will flash while door is unlocking, and then shut off when door has unlocked. Oven cavity will be hot to the touch. **DO NOT** attempt to open door prior to LOCKED indicator light shutting off.



Interrupting the self-clean cycle

To stop a self-clean cycle that has already started follow these steps. If the interruption occurs mid cycle, the oven will remain locked, even though the cycle has stopped, until the oven cavity has cooled to a safe temperature.

1. Turn oven temperature knob to OFF position.
2. When oven has cooled to a lower temperature, LOCKED light shuts off. Door can be unlocked. **DO NOT** force door. This can cause damage to the latch.

Baking Guidelines

When baking with a new oven, keep in mind temperatures vary from oven to oven. Store-bought thermometers are generally not accurate and should not be used to calibrate oven temperatures.

Hints for Cookies,

- Shiny, flat cookie sheets should be used. Avoid cookie pans with high sides - this will cause uneven browning on the top.
- Cookie sheet should not touch the sides of the oven or door.

Cakes,

- Follow recipe's directions for pan size. Shiny pans work best for cakes.
- Cake baked in too large a pan will be thin and dry. Too small a pan will be undercooked or unevenly cooked and may spill.

Pies

- Pies should be baked in dark or dull pans to increase browning.
- Frozen pies should be heated on an aluminum cookie sheet.

BAKING TIME GUIDELINES

Cake Pan Type	Pan size	Cups of batter	Oven Temp.	Minutes
Oval	7 ¾" x 5 ¾"	2 ½	350°F	25 to 30
	13" x 9 ¾"	8	350°F	25 to 30
Round, 2" layer	6"	2	350°F	25 to 30
	8 "	3	350°F	30 to 35
	14"	10	350°F	50 to 55
Round, 3" layer	8"	5	325°F	60 to 65
	12"	11	325°F	75 to 80
Half Round, 2" layer	18"	9	325°F	60 to 65
Half Round, 3" layer	18"	12	325°F	60 to 65
Square	6"	2	350°F	25 to 30
	10"	6	350°F	35 to 40
	16"	15 1/2	350°F	45 to 50

BAKEWARE GUIDELINES

Dark or dull pans	Absorb more heat and result in darker browning. Recommended for pies and breads.
Shiny pans (no sides)	Recommended for cookies.
Shiny pans (sides)	Recommended for cakes
Glass pans	Lower recommended oven temperature by 25°F.

Bake Pan Placement

- Keep pans and baking sheets 2 inches from oven walls.
- Stagger pans placed on different racks so one is not directly over the other.

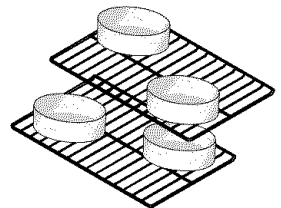

Preheating

In most cases, you should preheat the oven before baking. After the range control is set, the oven temperature will begin to rise until the desired cooking temperature is reached (approximately 8 to 10 minutes). When cooking temperature is reached oven signal beeps. **For delicate baking (such as puff pastries or souffles), preheat approximately 15–20 minutes before placing food inside oven or wait 10 minutes after oven signal beeps before placing food in oven.** The extra time creates a more stable oven temperature.

Cooking (cont'd)

Common Baking Problems

If you begin to notice consistent problems refer to the chart below for possible solutions. If results are still poor, contact **Amana Consumer Affairs at (800) 843-0304**.

Test your cakes for doneness

While they are still in the oven. Because of variances across individual ovens, it is best to test for the proper consistency rather than solely relying on time and visual appearance as an indicator.

It may not be the oven

Cake problems may be in the mixing of the batter. Overbeating can cause cake structure to break down and excessive shrinkage of the cake. Underbeating can result in lumpy cakes that may not be cooked thoroughly. All ingredients should be at room temperature—not out of the refrigerator. Make sure to follow the recipes directions for how long the batter should be mixed.

Cake stuck?

Allow cake to cool in cake pan on a rack for 10 minutes before removing. Larger cakes (over 14 inches in diameter) may take 15 minutes. If the cake has cooled too long, reheat in the oven at 250°F for a few minutes.

Better with butter

Make sure to follow recipe directions and use butter or margarine when it is listed. Using a low fat substitute will cause a recipe to fail.

Problem	Cause
Lopsided cakes (bake unevenly)	Pans touching each other or oven walls. Batter spread unevenly in pan. Uneven heat distribution in oven. Oven is not level.
Cakes, cookies, biscuits too brown on bottom or top	Oven not preheated. Pans touching each other or oven walls. Using glass, darkened, warped or dull finish metal pans. Rack position too high or low. Incorrect use of aluminum foil. Oven temperature too high.
Pies don't brown	Incorrect rack position. Using shiny metal pans. Temperature set too low.
Cakes not done in center	Temperature too high. Pan too small. Baking time too short. Pan not centered in oven.
Cakes fall	Too much shortening or sugar. Too much or too little liquid. Temperature too low. Old or too little baking powder. Pan too small. Oven door opened frequently (peeking). Insufficient baking.
Excessive shrinkage	Too little leavening. Mixing batter too long. Pan too large. Oven temperature too high. Baking time too long.
Cakes high in middle or cracked	Temperature set too high. Overmixing. Too much flour. Pans touching each other or oven walls.

Meat Basics

While cooking has always been a talent, it is now becoming a science, also. Amana provides this information as a guide to aid in preparation. For specific questions regarding meat preparation, handling, or storage contact **USDA (United States Department of Agriculture) Meat & Poultry Hotline at (800) 535-4555.**

Handling Hints

- When shopping, put meat in its own separate plastic sack to keep drips off other foods.
- Defrost frozen meats in refrigerator, not at room temperature.
- Keep meat cool and covered until it is time to cook.
- Wash hands with warm soapy water before and after handling meat or raw egg.
- Thoroughly wash any surface or utensil raw meat or egg touched.
- Do not put cooked meat on the same plate that held raw meat.

Cooking Tips

- Marinate meat in the refrigerator. Throw out excess marinade that came into contact with meat.
- Use an oven-proof meat thermometer.
- Cook meat to internal temperature recommended by USDA.
- When reheating foods, heat to an internal temperature of at least 165 °F.
- While cooking meats, turn over at least once.

Storage Safety

- Once carved, refrigerate unused portion immediately.
- Keep hot foods hot and cold foods cold when serving meals.
- Separate cooked foods into small portions for fast cooling.
- Do not store cooked ground meats or meals containing ground meats for longer than 3 to 4 days in the refrigerator.
- Do not allow cooked or uncooked meat juices to come into contact with ready-to-eat foods such as fruits or vegetables.

Tenderizing

Braising is only one way to tenderize less tender cuts. Before cooking, you may pound, cube, marinate, or use commercially prepared meat tenderizers. You may then use a dry method to cook the meat.

- **Marinades** are acidic liquids such as wine, citrus, or vinegar. Marinades soften meat fibers but only penetrate about one-fourth of an inch into the interior of the meat. Do not marinate meat for longer than 24 hours.
- **Pounding** with a heavy meat mallet breaks down the connective tissue to tenderize meat.
- **Cubing** breaks down the structure more than pounding. Cubing is done at the meat counter.
- **Commercial tenderizers** are primarily enzymes that work on the outer fourth inch on a meat cut. Make sure to follow the manufacturer's directions.

Using a Meat Thermometer

When using a meat thermometer, remember to insert it at a slight angle, in the thickest part of the meat, away from fat and bone. The meat should be removed when 5°F below the desired final temperature. While the meat sits before carving, it will continue to cook internally, raising the last 5°F by itself.

A meat thermometer can

- Take the guesswork out of cooking to a desired 'doneness'.
- Help reduce the risk of foodborne illness.

Oven-safe Thermometer

- Inserted before the meat is placed in the oven, this thermometer stays with the meat while it cooks.
- The internal temperature will rise slowly as the meat cooks.

Instant-read Thermometer

- Not oven safe, these thermometers are placed in the meat when it is removed from the oven.
- While times may vary, an accurate temperature is normally displayed within one to two minutes.
- When using an instant-read, remember to clean the thermometer stem with warm, soapy water between readings.

Cooking (cont'd)

Broiling Guidelines

Broiling is a dry heat cooking method that allows a restaurant quality charbroiled flavor. Meat is exposed directly to the heating element at high temperatures.

1. Place meat on rack in broiler pan, with the surface of cuts the specified distance from the heating element (specified below).
2. Broil for half the recommended time, or until the surface is browned.
3. Turn meat and continue broiling to desired internal temperature.
4. Season, if desired.

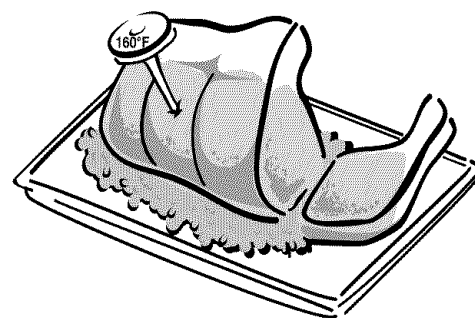

Meat Cut	Recommended Internal Temperature	Thickness (inches)	Weight (pounds)	Distance From Heat (inches)	Approximate Cooking Time (minutes)
----------	----------------------------------	--------------------	-----------------	-----------------------------	------------------------------------

BEEF

Chuck Shoulder Steak		¼ 1	¼ to 1 1 to 1 ¼	2 to 3 3 to 4	12 to 14 8 to 12
Rib Eye Steak	Very Rare 130°F Rare 140°F	¾ 1 1 ½	½ ½ to ¾ ¾ to 1	2 to 3 3 to 4 4 to 5	8 to 12 10 to 15 20 to 25
Sirloin Steak	Medium Rare 145°F Medium 160°F	¾ 1 1 ½	1 to 1 ¾ 1 ½ to 3 2 ¼ to 4	2 to 3 3 to 4 4 to 5	10 to 15 16 to 21 21 to 25
Porterhouse Steak	Well Done 170°F Very Well Done 180°F	¾ 1 1 ½	¾ to 1 1 ½ to 2 2 to 3	2 to 3 3 to 4 4 to 5	8 to 12 10 to 15 20 to 25
Filet Mignon (Tenderloin)		—	¼ to ½	2 to 4	10 to 15
Flank Steak		—	1 to 1 ½	2 to 3	12 to 14
Ground Beef Patties	160°F minimum	¾ to 1	1	3 to 4	10 to 15

PORK

Chops, bone in	All pork must be cooked to an internal temperature of at least 160°F to reduce the likelihood of Trichinosis. Failing to cook the meat to this temperature could result in personal injury or illness.	¾	—	4	6 to 8
Chops, boneless		¾	—	4	6 to 8
Tenderloin		—	½ to 1	4	15 to 25
Kabobs		1 inch cubes	—	4	10 to 20
Lean Ground Pork Patties		½	—	4	8 to 10

LAMB

Loin Chops	Medium 160°F Well Done 170°F	1	—	3 to 4	10 to 15
Rib Chops		1	—	3 to 4	10 to 15
Sirloin Steaks		1	—	3 to 4	12 to 15
Top Round Steaks		1	—	3 to 4	12 to 15
Center Leg Steaks		1	—	3 to 4	15 to 20
Cubes for Kabobs		1 ¼ pieces	—	3 to 4	10 to 15
Lamb Patties		½ x 4 inches	¼ each	3 to 4	12

All times and recommended temperatures are provided by the USDA, the Beef Industry Council, the National Pork Producer's Council, and the American Sheep Industry Council.

Roasting Guidelines

Tender cuts such as rib and loin cuts are best cooked by dry heat methods, such as roasting. To roast:

1. Heat oven to desired temperature.
2. Place roast directly from refrigerator fat side up in a shallow roasting pan.
3. Insert ovenproof meat thermometer so tip is centered in thickest part of roast. Make sure thermometer does not rest in fat or on bone.
4. Remove roast 5°F below desired degree of finished internal temperature.
5. Transfer roast to carving board and tent loosely with aluminum foil for approximately 15 minutes.

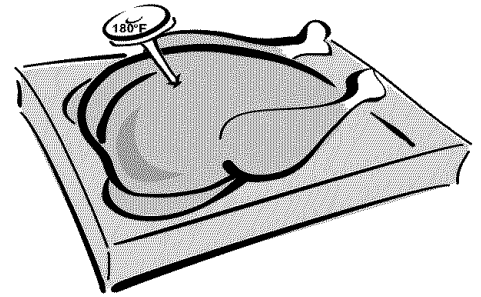

Meat Cut	Recommended Internal Temperature	Oven Temperature	Weight (pounds)	Approximate Cooking Time (minutes)
----------	----------------------------------	------------------	-----------------	------------------------------------

BEEF

Boneless Rump Roast	<table> <tr> <td>Very Rare</td> <td>130°F</td> </tr> <tr> <td>Rare</td> <td>140°F</td> </tr> <tr> <td>Medium Rare</td> <td>145°F</td> </tr> <tr> <td>Medium</td> <td>160°F</td> </tr> <tr> <td>Well Done</td> <td>170°F</td> </tr> <tr> <td>Very Well Done</td> <td>180°F</td> </tr> </table>	Very Rare	130°F	Rare	140°F	Medium Rare	145°F	Medium	160°F	Well Done	170°F	Very Well Done	180°F	325°F	4 to 6	25 to 30
Very Rare		130°F														
Rare		140°F														
Medium Rare		145°F														
Medium		160°F														
Well Done		170°F														
Very Well Done	180°F															
Tip Roast	325°F	3 ½ to 4	30 to 40													
Eye Round Roast	325°F	4 to 6	20 to 30													
Tenderloin Roast	425°F	2 to 3 4 to 6	35 to 45 45 to 60													
Rib Roast	325°F	4 to 6 6 to 8	26 to 42 23 to 35													
Rib Eye Roast	350°F	4 to 6	18 to 24													

PORK

Loin Roast, bone-in	All pork must be cooked to an internal temperature of at least 160°F to reduce the likelihood of Trichinosis and other food-borne illnesses.	350°F	3 to 5	20 minutes per pound
Rib Roast, boneless		350°F	2 to 4	
Tenderloin		450°F	½ to 1	
Ham bone-in, cook-before-eating		325°F	7 to 8	

LAMB

Shoulder	<table> <tr> <td>Medium-Rare</td> <td>150°F</td> </tr> <tr> <td>Medium</td> <td>160°F</td> </tr> <tr> <td>Well Done</td> <td>170°F</td> </tr> </table>	Medium-Rare	150°F	Medium	160°F	Well Done	170°F	325°F	3 ½ to 6	35 to 40
Medium-Rare		150°F								
Medium		160°F								
Well Done		170°F								
Rib Roast		375°F	1 ½ – 2 ½	30 to 35						
Rib Crown Roast, not stuffed	375°F	2 to 3	25 to 30							
Loin Roast	325°F	1 ¼ to 1 ¾	45 to 55							
Leg, Frenched Style or Half Shank	325°F	5 to 7 7 to 9	15 to 20 20 to 25							

POULTRY (unstuffed)

Capon	To reduce the risk of food-borne illnesses, poultry must be cooked to an internal temperature of 180°F.	325 to 350°F	4 to 8	20 to 30 min/lb.
Cornish Hens, whole		325 to 350°F	1 ¼ to 1 ½	50 to 60 total
Duck, whole		325 to 350°F	—	18-20 min/lb.
Goose, whole		325 to 350°F	—	20 to 25 min/lb.
Pheasant, whole		325 to 350°F	2	30 min/lb.
Quail, whole		325 to 350°F	—	20 minutes total
Turkey		325°F	8 to 16	3 ½ to 5 ½ hours

All times and recommended temperatures are provided by the USDA, the Beef Industry Council, the National Pork Producer's Council, and the American Sheep Industry Council.

Cooking (cont'd)

Braising Guidelines

Less tender cuts such as those from the round, chuck, brisket and shank require moist cooking. A longer cooking time at lower temperatures with moisture helps soften the meat.

1. Brown meat with a small amount of oil in heavy pan.
2. Pour off excessive drippings, season, if desired.
3. Add small amount of liquid (1/2 to 2 cups) and cover tightly.
 - Simmer gently over low heat on top of the range or in a 325°F oven, until meat is fork tender.

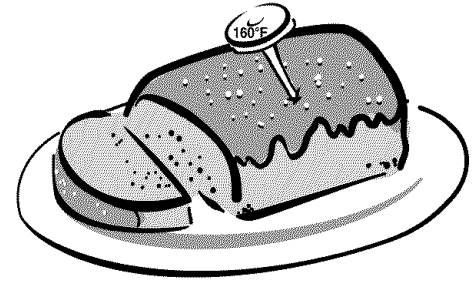

Meat Cut	Recommended Internal Temperature	Oven Temperature	Weight (pounds) OR Thickness	Approximate Cooking Time (hours)
BEEF				
Blade Pot Roast	Meat should be cooked to a temperature of at least 160°F to reduce the likelihood of food-borne illnesses.	325°F	3 to 5	1 ½ to 2
Arm Pot Roast		325°F	3 to 5	2 to 3
Chuck Roast (boneless)		325°F	3 to 5	2 to 3
Short Ribs		325°F	2 inches x 2 inches x 4 inches thick	1 ½ to 2 ½
Round Steak		325°F	¾ to 1 inch thick	1 to 1 ½
Flank Steak		325°F	1 ½ to 2 inches thick	1 ½ to 2 ½
LAMB				
Shoulder Chops, Round Bone or Blade	Meat should be cooked to a temperature of at least 160°F to reduce the likelihood of food-borne illnesses.	325°F	1 inch thick	1 to 1 ¼
Riblets		325°F	3 pounds	1 ½ to 2
Shanks		325°F	3 pounds	1 to 1 ½
Stew Cubes		325°F	1 inch pieces 1 ¼ lbs.	1 ¼ to 1 ½

All times and recommended temperatures are provided by the USDA, the Beef Industry Council, the National Pork Producer's Council, and the American Sheep Industry Council.

Care and Cleaning

Removing Oven Door

1. Fully open oven door.
2. Push hinge locks down toward door frame, to the unlocked position.
 - This may require a flatblade screwdriver.
3. Firmly grasp both sides of top of oven door.
4. Close door to first stop position.
5. Lift door up until hinge arm is clear of the slot.

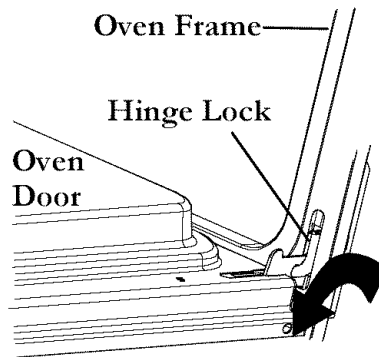

CAUTION

To avoid personal injury or property damage, handle oven door with care.

- Do not lift door by handle.
- Door is heavy and can be damaged if dropped.
- Screwdriver can scrape or chip range or oven finish.
- Do not scratch or chip glass or twist door. Glass may break suddenly.

Replacing Oven Door

1. Grasping door top firmly, seat indentation of hinge arm into bottom edge of the hinge slot.
 - Door should be at the first stop position angle.
2. Fully open oven door.
3. Push hinge locks up against the front frame of the oven cavity to locked position.
4. Close oven door.

Door Gasket

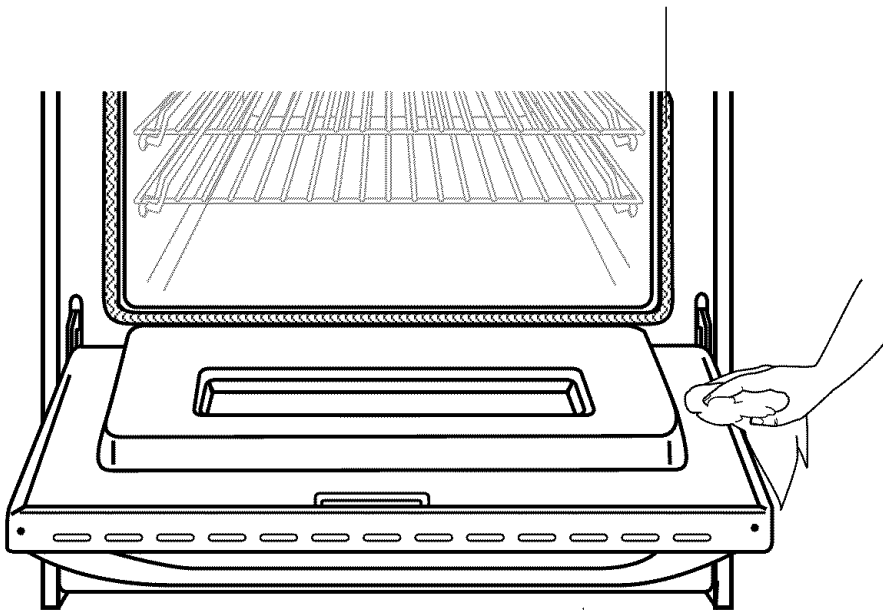

Cleaning Oven Door

Not all areas of the oven are cleaned by the self-clean cycle. The oven door, the gasket and area surrounding the gasket will not be cleaned effectively by the self-clean cycle. **DO NOT** use spray cleaners to clean the outside or inside of the oven door.

DO NOT clean the gasket. Do not wet, rub, soak or use any type of cleaning material to clean the oven gasket. Any damage or defects occurring from attempting to clean or remove the gasket are not covered by warranty.

To clean the area around the gasket make sure oven is cool to the touch. Using a cloth with a mild soap wipe area needing to be cleaned. Avoid gasket. Gasket should not be removed while cleaning. Do not allow water or cleaning solution to spill or drip onto gasket.

Removing Storage Drawer

1. Slide drawer out until it stops.
2. Remove stored items.
3. Grasp drawer sides near back of drawer.
4. Lift up and out. Reverse to reinstall.

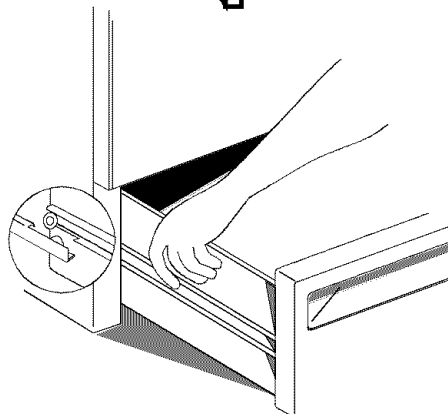

Care and Cleaning (cont'd)



WARNING

To avoid risk of burns or electrical shock:

- disconnect electrical supply to oven before changing light bulb.
- before replacing light bulb make sure oven and bulb are cool.
- do not operate oven without bulb and cover in place.







CAUTION

Wear gloves to protect hands from accidental bulb breakage.

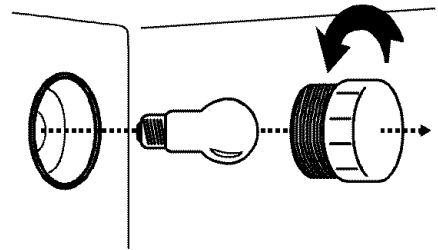
Replacing Oven Light

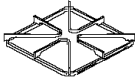
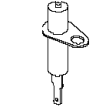
1. Disconnect electrical supply.
2. Remove oven door if desired.
3. While wearing protective gloves, unscrew counterclockwise the light bulb cover located in rear of oven cavity. Then turn light bulb counterclockwise to remove.
4. Replace light bulb with 120-volt, 40-watt appliance bulb. **Do not over tighten bulb or cover or they may be difficult to remove later.**
5. Replace light bulb cover and oven door before use.
6. Reconnect power supply.

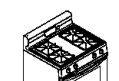
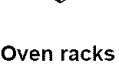

PART	GENERAL DIRECTIONS
Burner caps and grates 	<p>Cool before cleaning. Frequent cleaning with soap and water and a non abrasive pad prolongs time between deep cleanings. Be sure to dry thoroughly.</p> <p>For deep cleaning, place burner caps and grates in plastic bag with ½ cup ammonia. DO NOT pour ammonia into bag or allow ammonia to touch grates or caps. Close bag tightly and allow to sit overnight. Open bag pointed away from face to avoid fumes. Remove grates and caps and wash normally.</p>
Burner base 	<p>Allow to cool. Clean with warm soapy water and a clean cloth. If ports are clogged, clean with a toothbrush or a straight pin. Do not use a toothpick. Replace burner caps and turn on burners to check for proper operation.</p>
Electrode 	<p>Cool and remove burner grates and caps. Clean area around ceramic electrode with non-metallic utensil such as plastic pick, plastic straw or old toothbrush. Be sure there is no debris, burned fragments, or grease that may divert the spark or cause poor ignition. Do not pry on ceramic electrode</p>
Broiler pan and grid 	<p>Drain fat, cool pan and grid slightly. (Do not stand soiled pan and grid in oven to cool.) Sprinkle with soap. Fill the pan with warm water. Let pan and grid stand for a few minutes</p>
Control knobs 	<p>Pull off knobs. Wash gently with mild soap and water but do not soak. Dry and return knobs to oven, making sure to match flat area on the knob to the flat area on the shaft.</p>
Outside finish 	<p>Wash all glass with cloth dampened in soapy water. Rinse and polish with a dry cloth. If knobs are removed, do not allow water to run down inside surface while cleaning.</p>
Oven racks 	<p>For heavy soil, place oven racks in large plastic bag with ammonia and water in cup. Seal tightly and allow to stand overnight. Wash and rinse, dry thoroughly.</p>
Storage drawer 	<p>For heavy soil, clean by hand and rinse thoroughly. Remove drawer for ease in cleaning. Be sure drawer is dry before replacing.</p>

Care and Cleaning (cont'd)

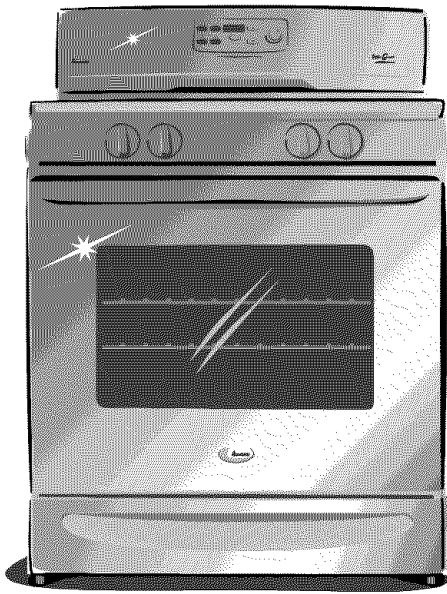

Cleaning Stainless Steel

Damage to stainless steel finish due to improper use of cleaning products, or using non-recommended cleaning products, is not covered under warranty. For Amana recommended products, call Consumer Affairs at 1(800) 843-0304 or online at www.amana.com.

Our stainless steel appliances have been factory finished for high shine and luster. To maintain this quality appearance:

DO NOT USE:

- Abrasive powders or liquids
- Citrus based cleaners
- Ammonia
- Steel wool pads
- Abrasive cloths
- Oven cleansers
- Acidic or vinegar based cleaners

DO USE:

- Warm soapy water for routine cleaning
- Soft clean cloths to dry or polish
- Stainless steel cleaner designed for appliances such as *Amana Cleaning Polish and Conditioner for Stainless Steel (#31960801)*



For best cleaning results

1. Wash surfaces with warm soapy water and a soft, clean cloth or sponge.
2. Rinse surfaces with warm water. Dry surfaces with a soft, clean cloth. **DO NOT** use the following harsh cleaners:
 - abrasive or acidic cleaners (ammonia, chlorine bleach, vinegar-based product, etc.)
 - citrus-based cleaners
 - scouring pads (metal, textured plastic, etc.)These items can scratch, discolor, or permanently tarnish surfaces.
3. Follow up rinsing by immediately drying with a soft, clean cloth. This will avoid water spotting on stainless steel finish.



Can I use liquid cleaners on my stainless steel?

Just because a cleaner is a liquid does not mean it is non-abrasive. Many liquid cleansers designed to be gentle on tile and smooth surfaces still damage stainless steel. Cosmetic damage from using non-recommended products is not covered under warranty.



Citric Acid

Citric acid permanently discolors stainless steel. To prevent damage to the finish of your stainless steel appliance, do not allow these substances to remain on the steel finish:

- mustard
- tomato juice
- marinara sauce
- citrus based sauces
- citrus based products



Questions? Comments?

Concerns? Contact us!

www.amana.com

or call Consumer Affairs at

1-800-843-0304

Troubleshooting

You may save time and money by checking items below before calling for service. List includes common concerns that are not the result of defective workmanship or materials. If your question is not explained below, contact Amana Consumer Affairs Department at **800-843-0304**.

Topic	Possible Cause	Solution
OPERATION		
Appliance not working	Power outage	Make sure appliance is plugged in. Verify that circuit breaker is not tripped. Replace household fuse but do not change fuse capacity.
	Oven door locked	Allow oven to cool for automatic lock to disengage. Once oven has unlocked, set oven to desired temperature.
Self clean shuts off during cycle	Using surface burners during self clean cycle	Surface burners should not be used during a self clean cycle. Set self clean cycle to delay when range does not need to be used.
Surface burner does not ignite	Poor cap placement	Turn control to OFF and follow directions in Placing Burner Cap section.
	Dirt or debris on electrode	Turn control to OFF and follow directions in Care and Cleaning section.
Broil cycle stops	Oven door open	Oven door must be closed during a broil cycle. Close oven door and broil cycle should resume normally.
Clock and timer not working	Power outage	Make sure appliance is plugged in. Verify that circuit breaker is not tripped. Replace fuse but do not change fuse capacity.
Oven light not working	Loose bulb	Check for loose bulb. Tighten.
	Burnt out bulb	Check for burnt out bulb. Replace if necessary with an appliance bulb.
Oven door will not unlock	Oven is self-cleaning	Allow cycle to complete or cancel function.
	Oven still hot	Will not unlatch until a certain cooler temperature has been reached. Do not force door open—will void warranty. May blow cooler air on latch with hair dryer at cool setting to quicken process.
Oven not clean after a self clean cycle	Too much soil, grime left in oven	Wipe out and remove excess soil prior to running self-clean cycle.
	Soot remains in oven after cycle	Normal. Wipe out with damp cloth.
Pans rock on surface burner grates	Warped pans	See Utensil section to check pan for flat bottom.
Locked light displayed	Door locked	If oven is hot, allow to cool rather than trying to force door latch open.
Display flashing	Power failure reset clock	Press CLOCK.
F-(numeric) display	Service code	Shut off power to oven for one to two minutes by switching off circuit breaker. Reset breaker. If continues, contact service department.
Oven smokes the first few times used	Normal	Minor smoking is normal the first few times the oven is used.

Troubleshooting (cont'd)

COOKING

Food not baking properly	Various causes	See <i>Cooking, Common Baking Problems</i>
Food not roasting properly	Various causes	See <i>Cooking, Roasting</i>
Food not broiling properly	Various causes	See <i>Cooking, Broiling</i>
Oven temperature too hot or cold	Calibrate oven temperature	See <i>Using the Oven Control, Oven Temperature Control Adjustment</i>
Oven has strong odor	Normal	Ovens will have a 'new' odor. Run a self-clean cycle to remove the odor.
Not boiling or cooking fast enough	Improperly sized cooking utensils	Make sure pans fit heating elements. See <i>Cookware Requirements</i> .

NOISE

Frequent cycling off and on of oven.	Normal	To maintain a temperature for baking, the oven cycles on and off.
Surface burners all click at once.	Normal	Ignitor sparks all burners when lighting a surface burner.
Cracking or popping sound	Normal	Wet cooking utensils or possible spillage. Expansion or contraction of oven during heating cycle. May be louder when using LP/Propane.

Amana Warranty

Full ONE Year Warranty

Amana Appliances will repair or replace, including related labor and travel, any part (f.o.b. Amana Iowa) which proves defective as to workmanship or materials.

Limited Warranty

After one year from the date of original retail purchase, Amana will provide a replacement part, as listed below, that fails due to a defect in materials or workmanship. The owner will be responsible for paying all other costs including labor, mileage, and transportation.

Second through Fifth Year

Amana will provide replacement gas surface burners, part only (f.o.b. Amana Iowa) which prove defective as to workmanship or materials.

What is not covered by these warranties

- Replacement of household fuses, resetting of circuit breakers, or correction to household wiring or plumbing.
- Normal product maintenance and cleaning, including light bulbs.
- Products with original serial numbers removed, altered, or not readily determined.
- Products purchased for commercial, industrial, rental, or leased use.
- Products located outside of the United States or Canada.
- Premium service charges, if the servicer is requested to perform service in addition to normal service or outside normal service hours or area.
- Adjustments after the first year.
- Repairs resulting from the following:
 - Improper installation, exhaust system, or maintenance.
 - Any modification, alteration, or adjustment not authorized by Amana.
 - Accident, misuse, abuse, fire, flood, or acts of nature.
 - Connections to improper electrical current, voltage supply, or gas supply.
 - Use of improper pans, containers, or accessories that cause damage to the product.

To Receive Warranty Service

Service must be performed by an authorized Amana service representative. To schedule service, contact the Amana dealer where you purchased your appliance or contact Amana Appliances Factory Service.

Amana Appliances Factory Service
1-800-628-5782 inside USA

**For more information,
Amana Appliances Consumer Services**
Amana Appliances
2800 220th Trail
Amana, Iowa 52204
1-800-843-0304 inside USA
(319) 622-5511 worldwide

When contacting Amana Appliances please include the following information:

- Your name, address, and telephone number.
- Model number and serial number of your appliance (found on right side of storage drawer opening).
- The name and address of your dealer and the date of purchase.
- A clear description of the problem.
- Proof of purchase (sales receipt).

IN NO EVENT SHALL AMANA BE LIABLE FOR INCIDENTAL OR CONSEQUENTIAL DAMAGES.

This warranty gives you specific legal rights, and you may have others which vary from state to state. For example, some states do not allow the exclusion or limitation of incidental or consequential damages, so this exclusion may not apply to you.

Amana Appliances Online • <http://www.amana.com>